

ORIGINAL CONTRIBUTION

Online Brand Attachment, Experience, and Sales Promotion Leads to Purchase Intention: Moderating Role of Online Brand Trust

Saqib Mehmood^{1*}, Madiha Hamid²

¹Faculty of Management Science, International Islamic University, Islamabad, Pakistan

²UCP Business School, University of Central Punjab, Lahore, Pakistan

Abstract— This research examines the impact of online brand experience on online brand trust and online repurchase intention. Additionally, the study tests whether online brand attachment moderates these influences. The study provides insights for online retail store managers to focus on improving the online experience for their customers to promote online brand trust and online repurchase intentions. This quantitative research, conducted as a cross-sectional study, investigates the dynamics of online consumer behaviour within the context of the Daraz online website in Pakistan. The study encompasses 530 participants who actively engage as shoppers on the platform. Utilizing a survey-based approach, the research explores the interplay between online brand attachment, online brand experience, purchase intention, the moderating role of online brand trust, and the mediating role of sale promotion. Employing the Smart PLS method for data analysis, the study contributes to the evolution of attachment theory within the digital marketing landscape. The background of the research centres on the unique online shopping environment provided by Daraz, a prominent online marketplace in Pakistan. The findings offer valuable insights for marketers seeking to enhance brand management strategies and optimize the online shopping experience to drive consumer attachment and purchase intentions in the competitive E-commerce landscape.

Index Terms— Online brand attachment, Online brand experience, Purchase intention, Online brand trust, Sale promotion

Received: 2 November 2023; **Accepted:** 17 December 2023; **Published:** 25 January 2024

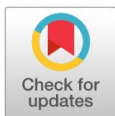

Introduction

Online purchasing is becoming increasingly popular every year, emerging as a significant trend. It offers a quick and comfortable substitute for offline purchasing, requiring users to visit stores (Muhammad, Kazi, & Munir, 2023) physically. Online shopping is convenient for several reasons, including its easy accessibility, capacity to save time and labour, lack of transportation-related problems, and, most importantly, its 24/7 availability. The transition to internet-based buying presents a noteworthy obstacle for conventional physical retail establishments (Ali, Ahmed, Afzal, & Ilyas, 2022). Many contend that because e-commerce is efficient, accessible accessible, round-the-clock, and has an intuitive user interface, it significantly outperforms traditional buying. Furthermore, online shopping is more economical (Jajja & Jat, 2019; Muhammad et al., 2023).

According to Ahmed (2020), the Asia-Pacific region has the most significant rate of online purchasing. In recent years, Pakistan has been one of the APAC countries with the fastest-growing e-commerce markets. E-commerce in Pakistan is still growing, according to

*Email: Saqib_ch3@yahoo.com

(Muhammad et al., 2023), and substantial future growth is predicted. The nation is home to over 100 e-commerce sites, generating billions of rupees in sales annually (Jajja & Jat, 2019). During the "Big Friday Sale" in 2017, even well-known platforms like daraz. Pk recorded an income of Rs. 3 billion (Ahmed, 2020). Managing Director of Nielsen Pakistan Quratulain Ibrahim reports that 82 per cent of consumers in developed areas with internet access had shopped online, a 7% rise from the previous year (Jajja & Jat, 2019). Moreover, Pakistan produced US\$4.2 billion in income from e-commerce in 2021, making it the 46th largest market (Ali et al., 2022). With US\$37.5 million in revenue in 2022, J. is the top player in the Pakistani e-commerce sector. The two largest stores, Gul Ahmed and LIMELIGHT, had US\$35.9 million and US\$34.2 million in revenue, respectively (Ali et al., 2022; Jajja & Jat, 2019; Muhammad et al., 2023).

With 4.5 billion users worldwide, or around 60% of the global population, internet connection is widely available. While Asia surpasses only Africa in terms of internet penetration rate, it has the highest number of internet users worldwide with a penetration rate of 54.2 percent, which is also lower than the global average of 58.8 percent (Ahmed, 2020). The causes are a combination of a lack of infrastructure and developing economies relative to developed regions like North America and Europe, with penetration rates of 89.4 and 87.7 percent, respectively. Pakistan has a mere 35 percent internet penetration rate among Asia's developing economies, far lower than the region's average (Jajja & Jat, 2019; Muhammad et al., 2023). Even though it might not seem like much, just 18% of Pakistanis used the internet in 2016 (Jajja & Jat, 2019; Muhammad et al., 2023). Considering the larger picture, the industry is expanding quickly. The recent arrival of 3G/4G technology, which has made internet accessible in remote locations where it was nonexistent before, has further increased this growth rate. This low penetration percentage makes studying a market in its quick expansion phase intriguing. This study aims to investigate Pakistani consumers' opinions regarding internet buying.

According to Dam (2020), four variables can be used to track customer behavior when they buy products online—perception, awareness, preparedness, and willingness. Marketing determines customer awareness by teaching them how to make payments on websites that sell goods online and obtain product information online (Chen & Yang, 2023; Putri & Anggarawati, 2022). The consumer demonstrates the willingness to purchase through an online store. When a consumer is prepared to decide, they are based on the first three elements. The Internet channel provides a different purchasing choice in the grocery market that works with the traditional in-store option. According to Chen and Yang (2023), users sometimes switch from one platform to another.

Furthermore, they assert that consumer behaviour is determined by their prior actions, regardless of the development of new technologies and e-commerce. Nothing can alter their preferences once a person has committed themselves fully to a brand. Online shopping complements traditional brick-and-mortar shopping (Helmi, Ariana, & Supardin, 2022; McClure & Seock, 2020; Montejó & Adriano, 2018; Yuanita & Marsasi, 2022).

Examining the idea of "brand attachment," which describes the bond between customers and brands, is fascinating. One of the most crucial aspects of brands is brand attachment. The fundamental mechanism of brand attachment occurs when a company offers hedonic resources, which makes consumers happy with the brand they buy (Xu, Jung, & Han, 2022; Yuanita & Marsasi, 2022). Due to their ability to satisfy utilitarian and hedonistic demands, brands are frequently purchased based only on emotions (Levy & Hino, 2016). People who have an emotional connection to a brand can gain self-discovery from the brands they enjoy. Thus, through attachment, consumer interaction can affect brand loyalty (Li, Teng, & Chen, 2020). Brand attachment can influence consumers' purchase of expensive, premium brands (Chen & Yang, 2023; Hidayati et al., 2021). To comprehend marketing, it is necessary to comprehend both the brand experience and the impact of brand attachment on customer retention (Ahmad & Akbar, 2023; Rabbane, Roy, & Spence, 2020). Customers' repurchase intention can be directly impacted by brand experiences that increase their sense of security (Chen & Yang, 2023; Hidayati et al., 2021). According to Chen and Yang (2023), brand experiences directly impact customers' intention to repurchase by fostering a sense of security. Chen and Yang (2023) research on brand attachment illuminates its significant influence on customer behaviour, from the first choice of brand to sustained brand loyalty and intent to repurchase.

Experience is critical in modern consumer behaviour (Pina & Dias, 2021; Yuanita & Marsasi, 2022). Experts in brand marketing always promote creative approaches to create a remarkable brand experience, strengthening the brand's favourable customer interactions (Husain, Paul, & Koles, 2022; Hwang, Choe, Kim, & Kim, 2021). "Subjective consumer responses evoked by specific brand-related experiential attributes in such settings" is how brand experience is defined (Akoglu & Özbek, 2022; Barijan, Ariningsih, & Rahmawati, 2021). Brand experience includes opinions about a company's identity, design, packaging, and other aspects at different consumer journeys. Brand experience's fundamental components are the sensory, affective, behavioural, and intellectual dimensions (Husain et al., 2022). Academics have embraced this multifaceted view of brand experience, making it easier to comprehend how each stimulus affects customer behaviour (Husain et al., 2022; Hwang et al., 2021). Furthermore, several research indicates that brand happiness is highly influenced by brand experience, which is retained in consumers' memories (Akoglu & Özbek, 2022; Husain et al., 2022).

Due to the recent global financial crisis, many retailers are turning to sales promotions as a critical strategy to increase declining sales and eliminate excess inventory (Wiranata & Hananto, 2020). Due to the regularity of these kinds of sales, even businesses like Starbucks—which would seem immune to the recession—have resorted to offering coupons to clients that are good for 50% off to draw them into their establishments. According to Helmi et al. (2022), there will be a greater propensity to employ sales promotions, especially as audiences become more dispersed and advertising costs continue to rise. Sales promotions stand out due to their capacity to

respond promptly, accurately, and adaptively to boost commerce or consumers and counteract the promotional activities of competitors (Bandyopadhyay, Sivakumaran, Patro, & Kumar, 2021).

Another important consideration is trust, which can sway someone's decision to buy (Puspaningrum, 2020). When given an option, consumers will almost certainly select a brand they are familiar with. Since education is expensive and inaccessible to everybody, price perceptions are significant (Benhardy, Hardiyansyah, Putranto, & Ronadi, 2020). Positive expectations regarding the intentions of other parties connected to a person in a risky circumstance are a prerequisite for trust (Benhardy et al., 2020). According to the research findings done by Dam (2020) and Hidayati et al. (2021), brand trust is critical to social media marketing. According to studies by Chen and Yang (2023), Cuong (2020), and Dam (2020), there is a substantial positive correlation between brand trust and brand loyalty. According to Dam (2020) and Hidayati et al. (2021), brand trust plays a significant role in fostering customer loyalty because it influences consumers' propensity to behave in ways that reflect their attitudes toward a brand. Companies can cultivate consumer emotion by using social media platforms to establish consumer trust in the goods or services they offer. This emphasizes how online brand attachment, experience, and sales promotion lead to purchase intention and the moderating role of online brand trust, as well as attachment theory.

Literature Review

With technological advancement, consumers are becoming more aware of the products and services (Kaatz, Brock, & Figura, 2019). As a result, brand experience has gained much attention from marketing researchers as it is an essential element of marketing strategies (Choi, Ok, & Hyun, 2017). Brand experience is the "defining stage or stage of events in which a company contacts in such manners that it creates a chain of events, and those chain of events then creates a memorable experience for the customers" (Fransen, Rompay, & Muntinga, 2013). Similarly, in an online context, marketers must understand the brand experience and its relationship with brand loyalty and repurchase intention. Previous studies show that online brand experience has emerged due to technological advancement (Foroudi, Gupta, Sivarah, & Broderick, 2018; Morgan-Thomas & Veloutsou, 2013). Retailers need to create and provide a unique brand experience that is developed quickly as the online environment and technology change (Khan, Rahman, & Fatma, 2016). Moreover, it is a challenge for marketers to overcome the problem of intangibility in a way that customers may overlook the tangible aspects of the products yet still experience the brand positively online (Bilgihan, Kandampully, & Zhang, 2016; García, Galindo, & Suárez, 2018)

Attachment theory

Bowlby first investigated the bond between newborns and their parents in 1958 to understand long-term human interactions (Johnson, 2019). The fact that Bowlby thought of playmate and attachment figures as conceptually separate roles is sometimes forgotten (Cherniak, Mikulincer, Shaver, & Granqvist, 2021). When youngsters are stressed, they are believed to seek out the attachment figure, but when feeling upbeat, they seek out a playmate. Since the two positions are not mutually exclusive, one individual (such as the caretaker) may fulfil both. This viewpoint has several ramifications for how attachment theory is put forward. First, even though playful interactions are crucial to mother-child relationships, it is evident that the term "attachment" in its more restrictive technical sense does not encompass the kinds of interactions examined by (Cherniak et al., 2021; Johnson, 2019). Stern, Barbarin, and Cassidy (2022) go into more detail on this topic. Second, it becomes clear that the variety of the partners' shared interaction plans or programs is a valuable method to characterize relationships. The use of attachment theory in adult romantic relationships is consistent with and a part of a broader revolution that has seen difficulties in adult romantic relationships and the relationships explored in scientific research. Science has finally started to confront the "core mysteries of human relationships," as noted by Cherniak et al. (2021), Johnson (2019), and Stern et al. (2022). The expanding body of recent research on the nature of relationship distress (Gottman, 2014) and the effects of close relationships on mental and physical health (Cherniak et al., 2021) align very nicely with attachment theory and related studies on adult attachment relationships.

Furthermore, it may be effortlessly combined with two essential viewpoints in the marital therapy approach: systems theory and the feminist perspective (Cherniak et al., 2021; Johnson, 2019; Stern et al., 2022). Nothing is more valuable than a solid theory, and attachment theory assists the couple therapist in navigating the intricate, multifaceted drama that is a close relationship in crisis. This is all aided by setting relevant and meaningful therapy goals and figuring out the best ways to assist. It also helps the therapist focus on the characteristics that define these kinds of relationships. According to Johnson (2019) and Stern et al. (2022), a topographical map can make the difference between a fantastic journey, getting lost in the woods, and reaching a dead end. Customers' connection to an online brand is likely stronger when they have faith in it, enhancing their overall experience, making them more receptive to discounts and promotions, and eventually leading to more purchases (Cherniak et al., 2021).

Online brand attachment

Brand attachment is the concept in which a consumer or individual seeks a sense of security from or relationship with a brand (Bahri-Ammari, Van Niekerk, Ben Khelil, & Chtioui, 2016). Attachment is the relationship process between the brand and the consumer (Japutra, Ekinci, & Simkin, 2018).

According to Ahmad and Akbar (2023), brand attachment is essential for developing a robust emotional and cognitive bond between the brand and the customer. The relationship between a brand and its customers includes feelings such as happiness, contentment, sadness, love, and discontent connected to the brand (Yuanita & Marsasi, 2022). When an artist presents their work live, it is seen as a cooperative and joyful activity involving the audience, the performers, and the music, exhibiting attachment-like qualities (Akbar, Ahmad, Asif, & Siddiqui, 2020). Essentially, brand attachment acts as a link between customers and the brand, fostering a meaningful and long-lasting relationship on an emotional and cognitive level. Simplistically stated, brand attachment is the emotional connection or link that exists between a person and a brand. Customers frequently form emotional bonds with companies, feeling various feelings with differing intensity, such as connection, passion, or affection. A vital component of brand attachment, this emotional bond signifies a solid and enduring affective bond with the brand (Rabbanee et al., 2020). In the context of brands, attachments are the sentimental and emotional ties that customers have with a particular brand. Consumers tend to personalize their brands and form strong bonds with them. Since brand attachment is predicted to impact behaviours that increase brand profitability and customer lifetime value, it is essential to measure the strength of the relationships that bind consumers to a brand. From a conceptual standpoint, brand attachment and ownership attachment are similar in that they view a brand as a source of feelings, identity, and historical values. The brand attachment has been defined by marketing researchers as the strength of the bond that unites the brand with the self. Its significance in promoting brand equity has been recognized (Hidayati et al., 2021). Strong attachments can arise from imagined or actual personal brand experiences, creating personalized meaning, trust, and autobiographical memories. The ties that bind the brand to the self are fundamentally emotional since these kinds of thinking are self-relevant (Akbar et al., 2020; Barijan et al., 2021). According to Hwang et al. (2021), brand attachment is a relationship-based term that denotes an emotional connection between a person and a brand.

Online brand experience

Online experiences have become an essential concept for marketing managers to understand to increase online repurchase intention and sales.

Making these relationships starts with customers meeting and using the brand. In the literature on experiential marketing, proposed the notion of brand experience, which has grown in significance. Husain et al. (2022) can be characterized as consumers' behavioural reactions and subjective internal responses (sensations, emotions, and cognition) to different stimuli related to a brand's design, identity, packaging, communication, and surroundings. In addition to interactions with print and electronic media, brand experiences can arise from shopping, purchasing, and direct consumption (Barijan et al., 2021). The four components of brand experience are sensory, emotive, intellectual (cognitive), and behavioural, according to Akoglu and Özbek (2022). The term "sensory brand experience" refers to how a consumer reacts to stimuli from a brand, such as touch, taste, smell, and sight. Consumer mood, emotions, and feelings are all part of the emotional brand experience, which is influenced by affective cues (Pina & Dias, 2021; Yuanita & Marsasi, 2022). To change consumers' impressions of a brand, intellectual brand experience entails getting them to think in new and convergent ways. By appealing to physical experiences, lifestyles, enduring behavioural patterns, or social connections, behavioural experience stimulates consumer behaviours or intents (Husain et al., 2022). These brand experience elements work together to create a comprehensive and exciting interaction between customers and the brand, laying the groundwork for long-lasting partnerships between the two. According to Akoglu and Özbek (2022), a brand's experience encompasses all of the sensations, emotions, thoughts, and reactions that a brand elicits in its audience. This includes the stimuli that come from a variety of sources, including marketing communications, brand design, brand identity, brand ambassadors, and the setting in which the brand is exhibited. Furthermore a brand's experience is the culmination of sensation, feeling, cognition, and behavioural reactions to stimuli pertaining to the brand's identity, packaging, communication, and external surroundings. The brand experience begins when customers start their product search, lasts through the decision-making process that results in the product purchase and lasts into the post-consumption stage. It also includes the many marketing tactics that the brand uses in relation to the goods or services that it provides (Akoglu & Özbek, 2022; Barijan et al., 2021). A brand's full impact on customers, from their first engagement to their post-purchase experiences and interactions with the company's marketing initiatives, is essentially captured by the term brand experience.

Sale promotion

One of the most important parts of marketing communication is sales promotion, which is meant to tell customers about the firm and increase their desire to buy goods and services (Ratih & Rahanatha, 2020). According to Akoglu and Özbek (2022), promotion is an

action-oriented marketing initiative that a company deliberately sets out to influence consumers and encourage them to make favourable purchase decisions or participate in product trials. Helmi et al. (2022) clarify in several sources that drawing in customers, educating them about the brand's goods and services, and swaying their decisions to buy are the main goals of promotion. Prior research has demonstrated that purchase intentions are significantly influenced by sales promotion (Akbar et al., 2020; Bandyopadhyay et al., 2021). Additionally, it is acknowledged that promotions play a big role in influencing what customers decide to buy (Pacheco & Rahman, 2015; Ratih & Rahanatha, 2020; Wiranata & Hananto, 2020). The promotion has an effect that goes beyond simple communication; it influences consumer behaviour and decision-making when it comes to purchasing products. One important component of the overall marketing strategy is sales promotion, which is strategically used to increase sales in the near term. Target audiences for this promotional strategy include customers (consumer sales promotion), members of the distribution channel (trade promotion), and sales personnel (sales force promotion) (Bandyopadhyay et al., 2021). Our research focuses only on sales promotions for consumers. A variety of strategies, including price cuts, discount coupons, bonus packs, sweepstakes, and competitions, are included in consumer promotion. Their goal is to entice and motivate customers (Ratih & Rahanatha, 2020).

Online brand trust

Trust is regarded as a key component when it comes to the development of brand attachment. Online brand trust, in other words, is a concept that can go beyond satisfaction between consumers and the brand.

The notion of brand trust in branding literature is closely linked to the viewpoint of the brand-consumer relationship (Barijan et al., 2021). The extant literature on branding has expounded upon diverse aspects of brand trust (Hidayati et al., 2021). According to one definition, trust is the degree to which customers believe that the seller's items are reliable and of high quality (Husain et al., 2022). Mahliza, Nugroho, Putra, et al. (2021) present an alternative viewpoint that defines brand trust as customers' readiness to depend on the brand's core values to achieve its stated goals. Comparably, brand trust is understood as a manifestation of belief throughout brand engagement, based on the consumer's anticipation that the brand would constantly be dependable and fulfilling (Puspaningrum, 2020). The literature on branding that is now available has presented many definitions of brand trust (Chen & Yang, 2023). Consumers' faith in a business's ability to deliver a high-quality and reliable product or service is known as trust (Husain et al., 2022). The idea that a brand will always be dependable and accountable for satisfying the customer is the foundation of brand trust, which is the state of feeling safe when interacting with the brand (Putri & Anggarawati, 2022; Sohail, Hasan, & Sohail, 2020; Xu et al., 2022). According to Dam (2020), brand trust is a measure of consumers' willingness to rely on a brand. The idea of trust was only appropriate in situations where there was uncertainty, such as when there were more significant discrepancies between brands than small ones. Because the buyer knew they could rely on the reputable brand, trust precisely reduced risk in circumstances where they felt particularly insecure. A buyer's readiness to rely on a brand in an uncertain situation because they anticipate positive outcomes from the brand is another definition of brand trust (Kamalasena & Sirisena, 2021). Essentially, when consumers are unclear about what to believe, trust helps to reduce ambiguity. It is founded on the expectation that the business would coordinate its operations with the wants and requirements of the customer. Customers who trust a business feel that their expectations will be fulfilled, which promotes dependability and keeps them from being let down. Conversely, brand trust pertains to the degree to which a consumer is willing to place their faith in a brand, particularly in the face of risk, in the hopes of achieving a favourable result (Kamalasena & Sirisena, 2021). Customers' faith in a company is a critical component of its success and well-being. In the end, trust is a crucial factor in determining how customers and businesses interact, acting as a cornerstone for constructive expectations and win-win situations.

Purchase intention

The true purpose of a buyer toward a product is known as buying intention. Purchase intention was described as a combination of the chance that a buyer will make a purchase and their level of concern. According to some earlier studies, purchase intention was highly correlated with desire and attitude toward a product or brand Xu et al. (2022). The possibility that consumers might plan to or be prepared to purchase a particular good or service in the future has also been referred to as purchase intention (Hidayati et al., 2021; Kamalasena & Sirisena, 2021). According to Cuong (2020), purchase intention indicates how consumers will behave predictably when making short-term future purchases (such as choosing a product or brand to buy when they go shopping) (Cuong, 2020; Dam, 2020)). Additionally, purchasing intention was defined as a customer's propensity to purchase a good. The larger the buying intention, the more a consumer intends to buy the product. Additionally, Cuong (2020) noted that perceptions and unforeseen events may also have an impact on a person's intention to purchase. Perceptions of a person's preferences and unforeseen events point to scenarios that alter buying intentions (Verma, 2021). The most often used indicator of customer behaviour prediction is purchase intention. Consumers are driven to consider carefully the promises made about brand involvement and brand love when formulating purchase intentions. Purchase intention is influenced by cognitive elaborations of brand involvement and high-quality brand-love information. Purchase intention and actual behaviour differ

(Cuong, 2020). Purchase intent for hotels is increased by brand equity. For neo-luxury brands, purchase intention has been influenced by brand love (Anjani & Astuti, 2022). For social media campaigns Cuong (2020), online communities Cuong (2020), and brands Cuong (2020), brand involvement positively increased purchase intentions. Purchase intention is influenced by equity (Hidayati et al., 2021; Kamalaseana & Sirisena, 2021). This study used the purchase intention measure developed by Cuong (2020).

Hypothesis development

The basic tenet of attachment theory is that people naturally seek close relationships with others to control their emotions and feel protected from psychological and bodily harm (Cherniak et al., 2021). People attach to brands to satisfy their needs for warmth, security, and comfort needs that are met by significant others, such as mothers, to whom attachment theory is frequently applied (Chen & Yang, 2023; Cherniak et al., 2021; Hidayati et al., 2021; Hwang et al., 2021). Barijan et al. (2021) make a compelling case for the need to know the meanings that customers ascribe to their belongings, saying that understanding consumer behaviour necessitates acknowledging things as essential components of the self. Given its critical role in shaping brand equity, marketing academics define brand attachment in this context as the strength of the tie tying the brand to the self (Rabbanee et al., 2020). Strong attachments can result from real or imagined personal brand experiences, which can create customized meaning, trust, and autobiographical memories. These linkages between the brand and the self are intrinsically emotional since these sentiments are self-relevant (Ahmad & Akbar, 2023; Akbar et al., 2020). Consumers' belief in a brand's goods or services is referred to as brand trust, according to Rabbanee et al. (2020). When a brand is seen as secure, dependable, and trustworthy, consumers typically show a high degree of brand trust Stern et al. (2022). According to Xu et al. (2022), brand trust can help customers feel less apprehensive about items and make more educated decisions about what to buy. Within the tourism industry, destination management is heavily influenced by visitors' brand trust. According to Yuanita and Marsasi (2022), travellers will have faith in places that make them feel at ease. Travelers are more likely to exhibit strong brand trust when their expectations are met throughout their trip (Akbar et al., 2020).

H1: There is a significant mediating impact of sale promotion between online brand attachment and purchase intention.

Hwang et al. (2021) define the brand experience as a collection of perceptions, emotions, thoughts, and actions brought on by stimuli associated with a brand and included in the design, identity, packaging, communications, and environments of the brand. Barijan et al. (2021) define brand experience as a dynamic process that allows consumers to identify or communicate their thoughts and feelings about a brand. In addition, the phrase "brand experience" describes a customer's initial or ongoing interactions with a brand through a range of media, such as images, tangible goods, and online platforms (Husain et al., 2022). Online shopping has grown in importance as a platform for marketers to understand and provide customers with a high-quality experience (Barijan et al., 2021). While consumers find online stores more convenient, marketers still struggle to comprehend consumer online purchasing habits and deliver a satisfying online brand experience (Pina & Dias, 2021; Yuanita & Marsasi, 2022). Online shoppers go through two stages, according to Barijan et al. (2021). The first step involves the buyer making their first online purchase from their chosen retailer. Depending on how satisfied you were with your first experience, the second step entails tracking your intention to make another purchase from the same online retailer. "The individual's judgments about buying a designated service from the same company again, taking into account his or her current situation and likely circumstances" is the definition of repurchase intention given by (Chen & Yang, 2023). However, clients can conduct pertinent information searches before making their first purchase from a particular online retailer (Anjani & Astuti, 2022; McClure & Seock, 2020). Repurchase intention, according to Hwang et al. (2021), goes beyond brand loyalty and shows that consumers develop a preference for a specific brand. Furthermore, as it costs five times more to acquire a new client than it does to maintain an existing one, marketers must come up with plans to increase customers' repurchase intention (Putri & Anggarawati, 2022). During the rapid adoption of e-commerce, a sizable corpus of work has focused on clarifying the notion of customer experience, specifically in relation to online customer experience (Verma, 2021; Xu et al., 2022). Several definitions of the customer experience have been proposed in this literature (Hidayati et al., 2021; Kamalaseana & Sirisena, 2021). While some research defines customer experience as customers' involvement in buying activities, others argue that customer experience is the range of emotions elicited during consumer-business interactions (Benhardy et al., 2020; Chen & Yang, 2023; Cuong, 2020; Dam, 2020).

H2: There is a significant mediating impact of sale promotion between online brand experience and purchase intention.

Ratih and Rahanatha (2020), it becomes clear that building brand trust is essential to creating a strong emotional connection between customers and the business and encouraging repeat business. It has to do with the brand's dependability, which is based on customers' trust that the product will live up to expectations (brand intention), which is based on customers' perception that the brand puts customers' needs first (Verma, 2021). By far, the most significant factor influencing a brand's worth is trust, which may either raise or lower the brand's overall value. As a result, consumers develop a sense of brand loyalty. Brand trust is a measure of a company's reliability and is derived from consumer confidence in the brand's capacity to fulfil commitments and prioritize the requirements of the customer (brand intention) (Wiranata & Hananto, 2020). By engaging with consumers, the brand responds to their needs and assumes liability for their safety and welfare. As a result, consumers feel quite secure with the brand. Perceived product quality that sticks in their recollections is

a sign of consumers' faith in the product, which is impacted by brand trust. As a result, customers are more likely to continue with the product and avoid moving to competitors. In addition to having the ability to forge valuable connections, brand trust becomes a crucial component in influencing consumer brand choices. Brand trust has a favourable and considerable influence on purchasing decisions, according to (Puspaningrum, 2020; Putri & Anggarawati, 2022). People's purchasing decisions rise in tandem with their perception of increased brand trust, demonstrating the crucial role that trust plays in influencing consumer behaviour. Customers who rely on a brand are more likely to pay more for it, buy new products that it endorses, stick with it, and share information about their preferences (Stern et al., 2022; Verma, 2021). Conversely, increased risk and uncertainty make customers feel less confident. As a result, stressing a pleasant brand experience will also reduce the likelihood that customers will see a danger and regard the brand as more reliable. As a result, this will affect their likelihood of becoming brand ambassadors as well as their level of brand loyalty (Wiranata & Hananto, 2020). Research indicates that trust is a key factor in determining purchase intention (Sohail et al., 2020).

H3: There is a significant impact of online brand trust on purchase intention.

In the world of internet retail, trust is crucial. "Trust is the cornerstone of the relationship between buyer and seller," as stated by Cuong (2020), "Trust enables [online customers] to understand the offering and to face the perceived risk associated with buying and consuming the product." Additionally, according to Putri and Anggarawati (2022), brand trust is the degree to which consumers are prepared to place their trust in a particular brand's dependability and integrity. It is the degree of trust that a client has in a particular brand's ability to provide the services or goods that they have been promised (Puspaningrum, 2020). Therefore, it is challenging for online retailers to realize their full potential if they do not earn the trust of their client (Puspaningrum, 2020; Putri & Anggarawati, 2022). Studies have shown that trust may be a crucial factor for internet-based businesses (Putri & Anggarawati, 2022; Sohail et al., 2020). According to Kamalasena and Sirisena (2021), brand trust is the belief that a company is trustworthy and accountable for the interests and well-being of its customers as well as the safe interactions that consumers have with their brands. The development of brand trust is contingent upon the brand's ability to instil confidence in customers regarding its worth. According to Benhardy et al. (2020), direct consumer experiences with brands have the power to both establish and foster brand trust. According to Dam (2020), trust in marketing terms is the propensity of a customer to return to a company. Trust is regarded as a crucial prerequisite for brands in the context of sale promotion and online purchases. According to Dam (2020), trust is the psychologically positive expectation that a consumer has of a brand. Compared to more conventional components of the promotion mix, consumers view social media as more reliable (Helmi et al., 2022). This could also be explained by direct communication, immediate feedback, and the generation of more objective content offered by sales promotion (Iqbal, 2020; Jajja & Jat, 2019). Compared to traditional means of promotion, consumers view social media as more dependable and trustworthy (Mahliza et al., 2021). Online brand attachments that offer dynamic conversation, immediate feedback, and more objective user-generated information could be a likely explanation for this. This study tries to fill a gap in the literature by thoroughly examining the relationship between online brand attachment purchase intention and sale promotion. One of the key components in encouraging consumer loyalty to a business is brand trust. Consumer confidence that the product can deliver on the promised value (brand intention), which is predicated on consumer confidence that the brand can put the needs of the customer first Putri and Anggarawati (2022), is the foundation of customer trust in a brand (brand reliability). Trust is the most important aspect of a brand that can affect how valuable people view it and inspire brand loyalty among consumers. According to Putri and Anggarawati (2022), brand trust is a factor that can cause consumers to form an emotional tie and loyalty to the company, as well as the ability of the brand to fulfil the interests of its consumers. According to Putri and Anggarawati (2022), a brand's ability to evoke strong emotions in its audience might persuade them to purchase it.

H4: There is a significant moderating impact of online brand trust on sale promotion and purchase intention.

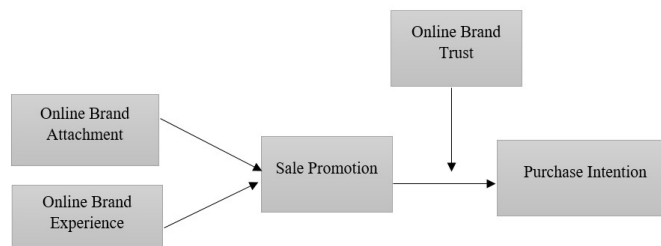

Fig. 1 Conceptual framework

Methodology

Design

This research is structured as a quantitative and descriptive study, with the objective of exploring the interrelationships among sale promotion, online brand attachment, online brand experience, online brand trust, and purchase intention among consumers of Daraz online in Pakistan. The cross-sectional design facilitates the evaluation of these relationships at a singular juncture, thereby offering a comprehensive overview of the dynamics among the variables under investigation. The primary emphasis is placed on the investigation and validation of hypotheses concerning these variables, employing a systematic and rigorous methodology for the collection and analysis of data.

Sample

The sample for this research consists of 530 participants sourced from the Daraz online marketplace in Pakistan. A non-probability convenience sampling approach was utilized to select these participants, as it provides practicality in engaging individuals who are readily accessible and willing to participate. This method, although effective, introduces potential biases that must be recognized. Despite these limitations, the selected sampling technique is designed to ensure a diverse representation within the sample, thereby enhancing the external validity of the study's results.

Instrumentation

To evaluate the primary variables of interest, a variety of adapted instruments were employed. The assessment of online brand attachment was conducted using six items that were adapted from Yuanita and Marsasi (2022). The measurement of online brand experience was further undertaken using another set of six items from the same authors. The evaluation of sale promotion, which serves as the mediating variable, was accomplished through three adapted items from Pacheco and Rahman (2015). The measurement of online brand trust, which acts as the moderating variable, was carried out using eight items that were adapted from Cuong (2020). Lastly, the assessment of purchase intention, the dependent variable, was conducted using four items that were adapted from Yuanita and Marsasi (2022). All variables were evaluated on a 5-point Likert scale, thereby enabling participants to indicate their level of agreement or disagreement with each statement.

Reliability and validity

The reliability and validity of the measurement instruments underwent a thorough assessment. The reliability of the instruments was established through the computation of Cronbach's alpha and Composite Reliability (CR), with all values surpassing 0.70 for each construct, signifying an adequate level of internal consistency. For the purpose of assessing convergent validity, the Average Variance Extracted (AVE) and factor loadings were scrutinized. Each item achieved a threshold of 0.50 for AVE and factor loadings, affirming the appropriateness of the constructs' convergent validity. This process ensures that the instruments reliably and accurately measure the intended variables.

Data collection

Data were gathered from 530 participants who were Daraz online shoppers in Pakistan via a structured questionnaire. The decision to employ this primary data collection method was made to secure direct responses from participants concerning their experiences and perceptions related to the variables under investigation. This strategy aids in the acquisition of pertinent and detailed information essential for the testing of research hypotheses.

Data Analysis

The analysis of data was executed employing Partial Least Squares Structural Equation Modeling (PLS-SEM) methodologies, facilitated by SmartPLS software. The analysis process was segmented into two primary stages: the initial evaluation of the measurement model to ensure the reliability and validity of the constructs, and the subsequent examination of the structural model to test the hypothesized relationships and hypotheses. This comprehensive analysis yielded insights into the determinants of online purchasing behavior among Daraz shoppers in Pakistan, thereby contributing significantly to the existing body of knowledge in the field.

Table I
Measurement model for convergent validity, AVE, and CR

Constructs	Items	Loadings	CA	CR	AVE
Online Brand Attachment	OBA1	0.734	0.849	0.890	0.578
	OBA2	0.800			
	OBA3	0.852			
	OBA4	0.782			
	OBA5	0.808			
	OBA6	0.545			
Online Brand Experience	OBE1	0.719	0.863	0.898	0.595
	OBE2	0.797			
	OBE3	0.788			
	OBE4	0.823			
	OBE5	0.776			
	OBE6	0.721			
Online Brand Trust	OBT1	0.802	0.913	0.930	0.623
	OBT2	0.809			
	OBT3	0.762			
	OBT4	0.791			
	OBT5	0.804			
	OBT6	0.819			
	OBT7	0.818			
Purchase Intention	PI1	0.892	0.872	0.921	0.796
	PI2	0.888			
	PI3	0.897			
Sale Promotion	SP1	0.854	0.879	0.926	0.807
	SP2	0.934			
	SP3	0.904			

Additionally, we assessed discriminant validity using the Fornell-Lacker standard (Hair Jr, Howard, & Nitzl, 2020). It connected the latent variable to the square root of the AVE values. Precisely, the AVE's square root ought to surpass its maximum correlation with every other build (Hair Jr et al., 2020). The reflecting constructs of brand happiness, brand trust, and purchase intention all had square roots of AVEs that were larger than the association of the corresponding latent variables, as table 2 demonstrated. As a result, these conceptions' discriminant validity was good.

Table II
Discriminant validity

	OBA	OBE	OBT	PI	SP
Online Brand Attachment	0.760				
Online Brand Experience	0.699	0.772			
Online Brand Trust	-0.632	-0.593	0.797		
Purchase Intention	0.662	0.595	-0.681	0.892	
Sale Promotion	0.676	0.657	-0.790	0.712	0.898

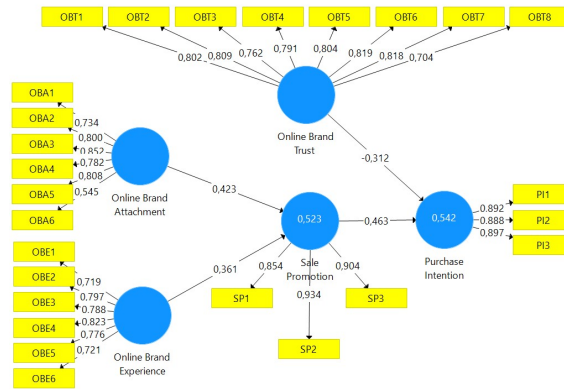

Fig. 2 Assessment of structural model

Assessment of structural model

The results of the hypothesis testing are displayed in tables 3 and 4. According to bootstrapping results (using 5000 resamplings) for the relationship between the constructs in the suggested study model, the H1, H2, H3, and H4 hypotheses all had *t*-values more than 1.96 and were significant at the 5% level. As such, these theories were validated. After the measurement model's validity and reliability have been demonstrated, the next stage is to evaluate the structural model inside the resulting framework. Hair, Risher, Sarstedt, and Ringle (2019) clarify the interactions between the latent variables proposed in the research model. Before proceeding with the structural model analysis, it is advisable to determine whether there are any collinearity problems between the latent variables. The Variance Inflation Factor (VIF) values are examined as part of the collinearity assessment process; a threshold of less than five is advised. The inner model's VIF values are shown in table 3, all of which are less than two. This suggests that there are no noteworthy problems regarding collinearity among the predictor variables. Thus, it can be concluded that collinearity problems have no negative impact on the structural model. There is a significant impact of online brand trust on purchase intention ($\beta = -0.132, p = 3.224$).

Table III
Direct relation

Relationships	Original Sample	<i>t</i> Statistics	<i>p</i> Values	Decision
H3 Online Brand Trust -> Purchase Intention	-0.312	3.224	0.001	Supported

The idea of mediation improves comprehension and description of the link between the two main elements. Understanding the mechanisms and underlying reasons for the link between these variables can be gained by analyzing the mediation effect. For a thorough analysis of mediated interactions and indirect effects of variables, structural equation modelling is utilized. To break down the sequence and clarify the impacts that have been noticed, a comprehensive analysis is necessary. Researchers can ascertain the importance of these mediation effects by assessing the routes. There is a significant mediating impact of sale promotion between online brand attachment and purchase intention ($\beta = 0.196, p = 3.664$). There is a significant mediating impact of sale promotion between online brand experience and purchase intention ($\beta = 0.167, p = 3.567$).

Table IV
Mediation relationship

Relationships	Original Sample	<i>t</i> Statistics	<i>p</i> Values	Decision
H1 Online Brand Attachment -> Sale Promotion -> Purchase Intention	0.196	3.664	0.000	Supported
H2 Online Brand Experience -> Sale Promotion -> Purchase Intention	0.167	3.567	0.000	Supported

Rather than being categorical, which usually entails multigraph analysis or demographic characteristics, the moderation effect is defined in the context of this research study as continuous moderation.

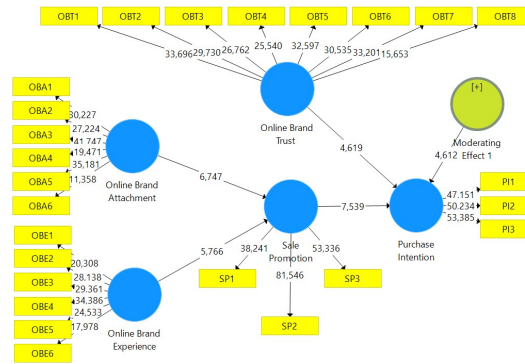

Fig. 3 Assessment of measurement model

According to Hair et al. (2019), "one specific relationship between two latent variables" is the focus of continuous moderation (p. 246). In many PLS-SEM investigations, the product indicator approach is the suggested method for calculating moderation effects; however, Hair et al. (2019) recommend using the two-stage approach by default. This method is preferred because it accurately and statistically represents the significance of the moderating impact. The findings show that there is a significant moderating impact of online brand trust on sale promotion and purchase intention ($\beta = 0.219, p = 4.612$).

Table V
Moderation relationship

Relationships	Original Sample	t Statistics	p Values	Decision
H4 Moderating Effect 1 -> Purchase Intention	0.219	4.612	0.000	Supported

Our results are consistent with earlier studies in the field of purchase intention, especially when examining the relationship between sales advertising and a firm's intention to buy, with an emphasis on the moderating role of online brand trust. In particular, our research shows that followers exhibit an ideal buy intention as promotional levels rise. A simple slope line with a moderate inclination in these situations indicates that the importance of online brand trust is slightly reduced (Hair et al., 2019; Hair Jr et al., 2020).

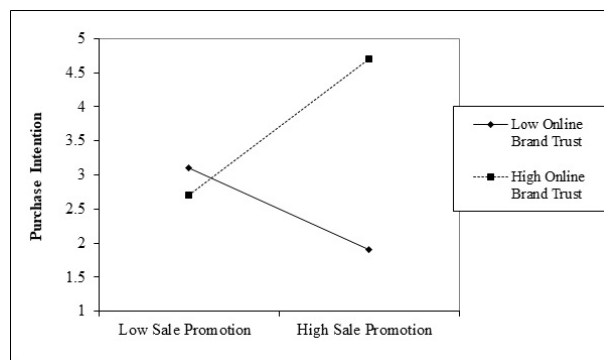

Fig. 4 Moderating effect of online brand trust

Discussion

The current study concludes that attachment theory evolved along with online brand attachment, online brand experience on purchase intention, the moderating effect of online brand trust, and the mediating impact of sale promotion. All hypotheses were accepted. The current study findings show that the four research model-proposed hypotheses were all supported.

The findings show that there is a significant mediating impact of sale promotion between online brand attachment and purchase intention ($\beta = 0.196, p = 3.664$). These findings show a comparable pattern in the relationship between brand attachment and consumer intention, which is in line with an earlier study by Akoglu and Özbek (2022) and Cuong (2020). More attachment is a reflection of a deeper love, passion, and connection to a brand, and when it reaches a particular intensity, it becomes an important factor in determining consumer intention (Barijan et al., 2021). There is a positive correlation between the degree of brand attachment and the probability of

customers selecting and buying that specific brand. This tendency is especially noticeable when people think a product from a brand will boost their confidence, which makes them choose and purchase it over products from other brands, even if the designs are comparable. When low-value promotions are presented, the differences in the effects of the two types of promotions appear to be far less pronounced than when high-value promotions are introduced. The lack of a noticeable difference in purchase intentions between the two marketing strategies implies that customers may use a merchant's reputation as a benchmark when assessing products, particularly if the merchant has a poor reputation. Customers may be less inclined to invest mental energy in closely contrasting each of the available promotions in such situations, instead choosing to base their choice on the retailer's overall reputation.

The findings show that there is a significant mediating impact of sale promotion between online brand experience and purchase intention ($\beta = 0.167, p = 3.567$). The investigation's results are consistent with those of studies by Mahliza et al. (2021) and Muhammad et al. (2023), highlighting the role that sensory experiences play in forming customers' perceptions, which then affect their intentions to make purchases (Hwang et al., 2021). The more positive encounters a consumer has with a brand, the more likely it is that they will choose it in the future. Interestingly, even when the quality and appearance of the two brands are equal, the one that makes a good first impression is more likely to be favoured and selected. When consumers are regularly satisfied with a brand or receive concrete benefits from it, positive stimuli are created. Stern et al. (2022) state that consumers create their purchase intentions and make decisions based on their entire integrated experience. Positive brand experiences, both during the purchase and during the use of a product, lead consumers to choose that brand more often when they go shopping.

The findings show that there is a significant impact of online brand trust on purchase intention ($\beta = -0.132, p = 3.224$). The research findings support this idea. It participates in investigations that bolster the conclusions of other studies (Cuong, 2020; Dam, 2020). In contrast to our findings, Benhardy et al. (2020) found in their study that brand experience has no bearing on brand trust. Similar to the findings of various study projects, it is typical for people who have interacted with a brand in the sports industry and are pleased with the terminology to have faith in it. Our findings are corroborated by studies in the literature (Hidayati et al., 2021). Sohail et al. (2020) state that research suggests a relationship between brand trust and purchase intention, which is crucial in encouraging customers to make additional purchases. According to Dam (2020), the long-term attributes of experience and brand trust provide a good explanation for this conclusion. Brand trust may be influenced by celebrity endorsements and advertising. Customers who have faith in a company are inclined to make repeat purchases and express intentions towards it.

The findings show that there is a significant moderating impact of online brand trust on sale promotion and purchase intention ($\beta = 0.219, p = 4.612$). Customers' faith in the reliability as well as the quality of the goods supplied by the vendor was defined as trust. According to Akbar et al. (2020), brand trust is described as customers' willingness to rely on the brand's sense of mission to achieve its stated objective. Similarly this, brand trust is a manifestation of the conviction that a brand will be able to please customers and remain dependable in the future (Cuong, 2020). Only in situations where there is risk is the concept of trust appropriate (e.g., in case of broader or smaller diversity among brands). Precisely, because the consumers knew they could depend on a reliable brand, confidence decreased in circumstances where they believed the goods to be extremely risky (Husain et al., 2022; Kamalaseena & Sirisena, 2021; Muhammad et al., 2023). Another definition of brand trust is a customer's propensity to rely on a brand in the face of uncertainty because they expect the brand to provide favorable results (Rabbanee et al., 2020; Sohail et al., 2020). On the other hand, when there is a low level of online brand trust, sales marketing plays a more significant role and is seen as having a greater impact on buy intention within the company. The intricate relationship that exists between sale marketing, buy intention, and online brand trust highlights the significance of building and preserving trust in the online brand environment and illuminates the nuances of consumer behaviour in the digital sphere. However, it is common for research results to vary across different businesses. In the context of our study, it makes sense for consumers to have faith in a brand of clothing if they have used it and are satisfied. This could be accounted for by the strong reputation that Daraz and other shopping brands we looked at have developed over time.

Theoretical and practical implications

The direct and indirect relationships between online brand experience, online brand attachment, online brand trust, sale promotion, and purchase intention are all integrated into a coherent model in this study, which contributes significantly to the theory. This thorough approach advances our knowledge of the ways in which these variables interact in the context of online retail, in contrast to previous research that looked at these relationships separately. The study provides an expanded framework for current theories of consumer behavior by filling in gaps in the literature. As a result, it offers a strong theoretical basis for further research into online consumer behavior and brand management by highlighting the connections between various brand-related factors.

The findings carry significant practical implications for marketing. Promoting new product lines, opening physical locations, or organizing exciting events are a few examples of tactics that marketers are urged to use to better engage consumers and actively manage their brand image. Customers' emotional ties to the brand are strengthened by these initiatives, which give them chances to engage with it. Furthermore, establishing community platforms can strengthen these connections and promote brand adherence. Building repurchase

intentions and brand trust can be achieved by managers giving priority to the creation of consistent and improved online brand experiences. The study makes a strong case for the moderating role of trust, emphasizing how building a reliable online presence can greatly increase the efficacy of marketing campaigns and provide businesses with a competitive advantage in the online market.

Limitations and future directions

It is important to take into account a few limitations when interpreting the study's findings. First off, the study's concentration on Pakistani persons who use sports items limits the generalizability of the findings and their relevance to other populations. Investigating other nations and demographics could improve external validity in subsequent study projects. Second, the moderating effect of online brand trust in the relationship between purchase intention and sale promotion is the sole focus of this study. Subsequent research endeavours ought to expand the purview by examining supplementary pivotal elements like brand image, brand awareness, recognized value, and so forth. Thirdly, a single survey instrument was used to gather data, with participants in Pakistan being the target audience. To improve methodological robustness, future work should collect data from several sources and combine longitudinal and experimental designs in a variety of scenarios. Another limitation is that the study's emphasis on the generic brand "Daraz" points to a possible direction for further research encompassing a wider range of actual and particular brands from other industries, including but not limited to platforms like Ali Baba or Ali Express. This would advance our understanding of the dynamics among various online brand settings more thoroughly. One key limitation is the relatively small sample size, which could impact the generalizability of the findings. Future research could solve this problem by performing studies with larger and more diverse samples that include a range of demographics and consumer interests. Furthermore, although offering insightful information, using Smart PLS for analysis has several drawbacks of its own. Subsequent investigations may investigate different statistical techniques or utilize a blend of techniques to verify and reinforce the resilience of the findings. Additionally, the study's focus was on particular elements of the online customer journey, like sale advertising and brand attachment. To provide a more thorough knowledge of the intricate dynamics impacting online consumer behaviour, future research initiatives could expand the analysis to include a wider variety of variables, such as brand image, perceived value, and customer happiness. The purpose of these considerations is to direct and stimulate further research endeavours that expand upon the groundwork established by the current study.

Conclusion

The study's main objective was to find the link of online brand experience with online brand trust and repurchase intention. The study also used brand attachment as a moderator in order to find the relationship between online brand experience, online brand trust and online repurchase intention.

The intricate links between online brand attachments, online brand experience, buy intention, online brand trust as a moderating factor, and sale promotion as a mediating component have all been made clearer by this study. The findings contribute to the growth of attachment theory concerning online branding. Marketers should also be aware of the significant ramifications of this research and employ proactive brand management strategies. Proposals for interactive events like fashion shows, new product lines, and storefront openings can serve as a source of inspiration for prospective clients and create opportunities for deeper customer relationships with the company. Customers benefit from being able to view and engage with the brand, which enhances their overall shopping experience. Adopting such strategic tactics will be essential for marketers hoping to develop strong brand connections, promote great online experiences, and ultimately drive purchase intentions in the cutthroat online marketplace as the digital landscape continues to change. The results of the current study suggest significant impact of online brand experience on online purchase intention and online brand trust. The study also confirms that online brand attachment acts as a moderator in the a relationship that online brand experience has with online purchase intention and online brand trust

References

- Ahmad, B., & Akbar, M. I. u. D. (2023). Validating a multidimensional perspective of relationship marketing on brand attachment, customer loyalty and purchase intentions: A serial mediation model. *Journal of Strategic Marketing*, 31(3), 669-692.
- Ahmed, W. (2020). *An investigation into customer preferences for online shopping in South Asia (Pakistan): A case study of Daraz.pk* (Tech. Rep.). Vantaa, Finland: Laurea University of Applied Sciences.
- Akbar, M. I. U. D., Ahmad, B., Asif, M. H., & Siddiqui, S. A. (2020). Linking emotional brand attachment and sales promotion to post-purchase cognitive dissonance: The mediating role of impulse buying behavior. *The Journal of Asian Finance, Economics and Business*, 7(11), 367-379. doi:https://doi.org/10.13106/jafeb.2020.vol7.no11.367
- Akoglu, H. E., & Özbek, O. (2022). The effect of brand experiences on brand loyalty through perceived quality and brand trust: A study on sports consumers. *Asia Pacific Journal of Marketing and Logistics*, 34(10), 2130-2148. doi:https://doi.org/10.1108/apjml-05-2021-0333
- Ali, A., Ahmed, I. A., Afzal, A., & Ilyas, Z. (2022). Comparison of usability level of e-commerce websites: Daraz and homeshopping. *Pakistan Journal of Engineering and Technology*, 5(2), 211-215. doi:https://doi.org/10.51846/vol5iss2pp211-215
- Anjani, D., & Astuti, R. (2022). The effect of brand engagement and brand love upon overall brand equity and repurchase intention: Case study on smartphone brands in Indonesian millennials. In *Contemporary research on management and business*. Boca Raton, FL: CRC Press.
- Bahri-Ammari, N., Van Niekerk, M., Ben Khelil, H., & Chtioui, J. (2016). The effects of brand attachment on behavioral loyalty in the luxury restaurant sector. *International Journal of Contemporary Hospitality Management*, 28(3), 559-585.
- Bandyopadhyay, N., Sivakumaran, B., Patro, S., & Kumar, R. S. (2021). Immediate or delayed! Whether various types of consumer sales promotions drive impulse buying?: An empirical investigation. *Journal of Retailing and Consumer Services*, 61, 102532. doi:https://doi.org/10.1016/j.jretconser.2021.102532
- Barijan, D., Ariningsih, E. P., & Rahmawati, F. (2021). The influence of brand trust, brand familiarity, and brand experience on brand attachments. *Journal of Digital Marketing and Halal Industry*, 3(1), 73-84. doi:https://doi.org/10.21580/jdmhi.2021.3.1.7440
- Benhardy, K., Hardiyansyah, H., Putranto, A., & Ronadi, M. (2020). Brand image and price perceptions impact on purchase intentions: Mediating brand trust. *Management Science Letters*, 10(14), 3425-3432. doi:https://doi.org/10.5267/j.msl.2020.5.035
- Bilgihan, A., Kandampully, J., & Zhang, T. (2016). Towards a unified customer experience in online shopping environments: Antecedents and outcomes. *International Journal of Quality and Service Sciences*, 8(1), 102-119. doi:https://doi.org/10.1108/ijqss-07-2015-0054
- Chen, N., & Yang, Y. (2023). The role of influencers in live streaming e-commerce: Influencer trust, attachment, and consumer purchase intention. *Journal of Theoretical and Applied Electronic Commerce Research*, 18(3), 1601-1618. doi:https://doi.org/10.3390/jtaer18030081
- Cherniak, A. D., Mikulincer, M., Shaver, P. R., & Granqvist, P. (2021). Attachment theory and religion. *Current Opinion in Psychology*, 40, 126-130. doi:https://doi.org/10.1016/j.copsyc.2020.08.020
- Choi, Y. G., Ok, C. M., & Hyun, S. S. (2017). Relationships between brand experiences, personality traits, prestige, relationship quality, and loyalty: An empirical analysis of coffeehouse brands. *International Journal of Contemporary Hospitality Management*, 29(4), 1185-1202. doi:https://doi.org/10.1108/ijchm-11-2014-0601
- Cuong, D. T. (2020). The role of brand trust as a mediator in the relationship between brand satisfaction and purchase intention. *International Journal of Psychosocial Rehabilitation*, 24(6), 14726-14735.
- Dam, T. C. (2020). Influence of brand trust, perceived value on brand preference and purchase intention. *The Journal of Asian Finance, Economics and Business*, 7(10), 939-947. doi:https://doi.org/10.13106/jafeb.2020.vol7.no10.939
- Foroudi, P., Gupta, S., Sivarajah, U., & Broderick, A. (2018). Investigating the effects of smart technology on customer dynamics and customer experience. *Computers in Human Behavior*, 80, 271-282. doi:https://doi.org/10.1016/j.chb.2017.11.014

- Fransen, M. L., Rompay, T. J. v., & Muntinga, D. G. (2013). Increasing sponsorship effectiveness through brand experience. *International Journal of Sports Marketing and Sponsorship*, 14(2), 37-50. doi:https://doi.org/10.1108/ijSMS-14-02-2013-b004
- García, J. A. C., Galindo, A. D. V., & Suárez, R. M. (2018). The effect of online and offline experiential marketing on brand equity in the hotel sector. *Spanish journal of marketing-ESIC*, 22(1), 22-41. doi:https://doi.org/10.1108/sjme-03-2018-003
- Gottman, J. M. (2014). *What predicts divorce?: The relationship between marital processes and marital outcomes*. East Sussex, England: Psychology Press.
- Hair, J. F., Risher, J. J., Sarstedt, M., & Ringle, C. M. (2019). When to use and how to report the results of PLS-SEM. *European business review*, 31(1), 2-24. doi:https://doi.org/10.1108/ebr-11-2018-0203
- Hair Jr, J. F., Howard, M. C., & Nitzl, C. (2020). Assessing measurement model quality in PLS-SEM using confirmatory composite analysis. *Journal of Business Research*, 109, 101-110. doi:https://doi.org/10.1016/j.jbusres.2019.11.069
- Helmi, S., Ariana, S., & Supardin, L. (2022). The role of brand image as a mediation of the effect of advertising and sales promotion on customer purchase decision. *Journal of Economics and Sustainable Development*, 13(8), 90-99. doi:https://doi.org/10.7176/jesd/13-8-09
- Hidayati, A. N., et al. (2021). The effect of nostalgia emotion to brand trust and brand attachment towards repurchase intention. *Turkish Journal of Computer and Mathematics Education (TURCOMAT)*, 12(3), 4492-4503. doi:https://doi.org/10.17762/turcomat.v12i3.1836
- Husain, R., Paul, J., & Koles, B. (2022). The role of brand experience, brand resonance and brand trust in luxury consumption. *Journal of Retailing and Consumer Services*, 66, 102895. doi:https://doi.org/10.1016/j.jretconser.2021.102895
- Hwang, J., Choe, J. Y. J., Kim, H. M., & Kim, J. J. (2021). Human baristas and robot baristas: How does brand experience affect brand satisfaction, brand attitude, brand attachment, and brand loyalty? *International Journal of Hospitality Management*, 99, 103050. doi:https://doi.org/10.1016/j.ijhm.2021.103050
- Iqbal, M. (2020). Factors influencing the attitude and word of mouth of Pakistani online shoppers. *International Journal of Academic Management Science Research (IJAMSR)*, 4 1(5), 29-38.
- Jajja, M. S. S., & Jat, M. N. (2019). Daraz. pk: Online marketplace's value chain. *Asian Journal of Management Cases*, 16(1), 21-37. doi:https://doi.org/10.1177/0972820119825976
- Japutra, A., Ekinci, Y., & Simkin, L. (2018). Positive and negative behaviours resulting from brand attachment: The moderating effects of attachment styles. *European Journal of Marketing*, 52(5/6), 1185-1202.
- Johnson, S. M. (2019). *Attachment theory*. New York, NY: Springer.
- Kaatz, C., Brock, C., & Figura, L. (2019). Are you still online or are you already mobile?-Predicting the path to successful conversions across different devices. *Journal of Retailing and Consumer Services*, 50, 10-21. doi:https://doi.org/10.1016/j.jretconser.2019.04.005
- Kamalasena, B., & Sirisena, A. (2021). The impact of online communities and E word of mouth on purchase intention of generation Y: The mediating role of brand trust. *Sri Lanka Journal of Marketing*, 7(1), 92-116. doi:https://doi.org/10.4038/sljmuok.v7i1.58
- Khan, I., Rahman, Z., & Fatma, M. (2016). The role of customer brand engagement and brand experience in online banking. *International Journal of Bank Marketing*, 34(7), 1025-1041. doi:https://doi.org/10.1108/ijbm-07-2015-0110
- Levy, S., & Hino, H. (2016). Emotional brand attachment: A factor in customer-bank relationships. *International Journal of Bank Marketing*, 34(2), 136-150. doi:https://doi.org/10.1108/ijbm-06-2015-0092
- Li, M.-W., Teng, H.-Y., & Chen, C.-Y. (2020). Unlocking the customer engagement-brand loyalty relationship in tourism social media: The roles of brand attachment and customer trust. *Journal of Hospitality and Tourism Management*, 44, 184-192. doi:https://doi.org/10.1016/j.jhtm.2020.06.015
- Mahliza, F., Nugroho, L., Putra, Y. M., et al. (2021). The effect of e-wom, brand trust, and brand ambassador on purchase decisions at tokopedia online shopping site. In *Iop conference series: Materials science and engineering* (Vol. 1071, p. 012017).
- McClure, C., & Seock, Y.-K. (2020). The role of involvement: Investigating the effect of brand's social media pages on consumer purchase intention. *Journal of Retailing and Consumer Services*, 53, 101975.

- Montejo, G. M., & Adriano, T. Q. (2018). A critical discourse analysis of headlines in online news portals. *Journal of Advances in Humanities and Social Sciences*, 4(2), 70-83. doi:<https://doi.org/10.20474/jahss-4.2.2>
- Morgan-Thomas, A., & Veloutsou, C. (2013). Beyond technology acceptance: Brand relationships and online brand experience. *Journal of Business Research*, 66(1), 21-27. doi:<https://doi.org/10.1016/j.jbusres.2011.07.019>
- Muhammad, J., Kazi, A. K., & Munir, S. (2023). Artificial intelligence and e-commerce: An empirical investigation of Daraz Pakistan. *Pakistan Languages and Humanities Review*, 7(4), 694-702. doi:[https://doi.org/10.47205/plhr.2023\(7-iv\)60](https://doi.org/10.47205/plhr.2023(7-iv)60)
- Pacheco, B. G., & Rahman, A. (2015). Effects of sales promotion type and promotion depth on consumer perceptions: The moderating role of retailer reputation. *The International Review of Retail, Distribution and Consumer Research*, 25(1), 72-86. doi:<https://doi.org/10.1080/09593969.2014.918047>
- Pina, R., & Dias, Á. (2021). The influence of brand experiences on consumer-based brand equity. *Journal of brand Management*, 28(2), 99-115. doi:<https://doi.org/10.1057/s41262-020-00215-5>
- Puspaningrum, A. (2020). Social media marketing and brand loyalty: The role of brand trust. *The Journal of Asian Finance, Economics and Business*, 7(12), 951-958. doi:<https://doi.org/10.13106/jafeb.2020.vol7.no12.951>
- Putri, A. M. P., & Anggarawati, S. (2022). The role of brand trust as a mediator in the relationship between social media marketing and purchase intentions. *Managament Insight: Jurnal Ilmiah Manajemen*, 17(2), 217-232.
- Rabbanee, F. K., Roy, R., & Spence, M. T. (2020). Factors affecting consumer engagement on online social networks: self-congruity, brand attachment, and self-extension tendency. *European Journal of Marketing*, 54(6), 1407-1431. doi:<https://doi.org/10.1108/ejm-03-2018-0221>
- Ratih, P. A. R., & Rahanatha, G. B. (2020). The role of lifestyle in moderating the influence of sales promotion and store atmosphere on impulse buying at Starbucks. *American Journal of Humanities and Social Sciences Research (AJHSSR)*, 4(2), 19-26.
- Sohail, M. S., Hasan, M., & Sohail, A. F. (2020). The impact of social media marketing on brand trust and brand loyalty: An Arab perspective. *International Journal of Online Marketing (IJOM)*, 10(1), 15-31. doi:<https://doi.org/10.4018/ijom.2020010102>
- Stern, J. A., Barbarin, O., & Cassidy, J. (2022). Working toward anti-racist perspectives in attachment theory, research, and practice. *Attachment & Human Development*, 24(3), 392-422. doi:<https://doi.org/10.1080/14616734.2021.1976933>
- Verma, P. (2021). The effect of brand engagement and brand love upon overall brand equity and purchase intention: A moderated-mediated model. *Journal of Promotion Management*, 27(1), 103-132. doi:<https://doi.org/10.1080/10496491.2020.1809591>
- Wiranata, A. T., & Hananto, A. (2020). Do website quality, fashion consciousness, and sales promotion increase impulse buying behavior of e-commerce buyers? *Indonesian Journal of Business and Entrepreneurship (IJBE)*, 6(1), 74-85. doi:<https://doi.org/10.17358/ijbe.6.1.74>
- Xu, W., Jung, H., & Han, J. (2022). The influences of experiential marketing factors on brand trust, brand attachment, and behavioral intention: Focused on integrated resort tourists. *Sustainability*, 14(20), 13000. doi:<https://doi.org/10.3390/su142013000>
- Yuanita, A. D., & Marsasi, E. G. (2022). The effect of brand attachment, brand experience, and self-image congruence on the purchase intention of luxury brand. *Jurnal Ekonomi Bisnis dan Kewirausahaan (JEBIK)*, 11(3), 292-310. doi:<https://doi.org/10.26418/jebik.v11i3.57542>